



OWNER'S MANUAL

FIRST 21.7

FR-BEY _ _ _ _ _

BENETEAU REF : ./

SUMMARY:

I) INTRODUCTION.....	3
II) IDENTITY CARD OF THE BOAT	4
III) ACCOMMODATION.....	6
IV) DECK (Location of the life raft)	8
V) SAILS AND RIGGING.....	9
VI) FRESH WATER SYSTEM.....	12
VII)BILGE PUMP SYSTEM	14
VIII) SEACOCKS AND SKIN FITTINGS.....	16
IX) ELECTRIC SYSTEMS	17
X) GAS SYSTEM.....	20
XI) EMERGENCY SYSTEM OF THE STEERING SYSTEM.....	22
XII) MOTORIZATION	23
XIII) HANDLING	25
XIV) MAINTENANCE.....	26
XV) ENVIRONMENT	29
XVI) CENTREBOARD SYSTEM.....	30

EXPLANATION OF THE TYPOGRAPHY USED:

DANGER

WARNING

TAKE CARE

RECEIPT

OWNER'S NAME

ADDRESS

.....

.....

Owner of the FIRST 21.7 n°

Do certify that I have accepted delivery and read the information in the owner's manual delivered with the boat.

On

Signature

Please keep this copy for your records



RECEIPT

OWNER'S NAME :

ADDRESS :

.....

.....

Owner of the FIRST 21.7 n°

Do certify that I have taken delivery and read the information in the owner's manual delivered with the boat.

On

Signature

Please send back this copy to CHANTIERS BENETEAU S.A
ZI des Mares BP66
85270 Saint Hilaire de Riez
FRANCE

I) INTRODUCTION

Dear Madam, Dear Sir,

You have just taken delivery of your new BENETEAU boat and we would like to congratulate you first of all for the confidence you showed to us in choosing a product of our mark.

A BENETEAU boat is built to last : each boat is subject to particular care in the slightest details, as early as when she is designed, when she leaves the factory and she is launched ; this way, she will come up to your expectations for many years.

This manual was meant to help you to enjoy your boat safely. You will find in it the details of your boat , her fittings and information about the use and maintenance. Read it carefully and get to know her before you put out to sea.

If this is your first boat, or if you change to a new type of boat (to which you are not used) get some training to control and sail her , to ensure your safety and comfort. Then you will be able to assume the command of the boat. Your dealer, your national sailing association or your Yacht club will be very happy to recommend you local sailing schools or professional instructors.

Have fine and safe sailing time.

(1) Throughout their lives, our boats are regularly improved and benefit from our experience and our customers' experience ; therefore the specifications given in this owner's manual are not contractual and may be modified without prior notice and up dating obligation.

In the same way, this manual has a general purpose and it may sometimes list some equipments or refer to some points which are not relevant to your own boat. In case of doubt, you shall always refer to the inventory list.

KEEP THIS MANUAL IN A SAFE PLACE AND HAND IT OVER TO THE NEW OWNER IF YOU SELL THE BOAT.
--

II) IDENTITY CARD OF THE BOAT

Type FIRST 21.7
 Name of Builder CHANTIERS BENETEAU SA
 Design Category B
 N° of acknowledged body CE 0607

Length of Hull	6.25 m
Over All Beam	2.48 m
Draught: Shallow :	0.70 m
Deep:	1.80 m
Clearance Height	10.40 m

Maximum Authorized Engine Power :	8 kW
-----------------------------------	------

Fresh Water Capacity	35 Litres
Battery Capacity	45 Amp

Category	Height of Waves (m)	Wind Force (Beaufort)
A	> 4	> 8
B	< 4	≤ 8
C	< 2	≤ 6
D	< 0.5	≤ 4

For additional information concerning the fitted equipment, please refer to their manuals enclosed in the boat literature.

Maximum recommended number of persons on board by design category:

Category	Number of persons
A	
B	4
C	6
D	6

The equipments of the C.E. Certified boat are : The fuel tanks, the parts of the steering system, the parts of the gas system and the hatches and portholes.

(1)

WEIGHT ESTIMATION

SAILING CATEGORIES	A	B	C	D
Light Boat :		1185	1185	1185
Safety Equipment :		45	45	45
Sail :		15	15	15
Light Displacement :		1245	1245	1245
Minimum Crew :		75	75	75
Life Raft :		30	30	30
Rest of Crew :		225	225	225
Personal Equipment:		125	125	125
Optional Equipment (6 HP Outboard Engine)		40	40	40
Margin for Extra Equipment :		45	45	45

MAXIMUM LOAD DISPLACEMENT (Kg)	1785	1785	1785
---------------------------------------	-------------	-------------	-------------

MAXIMUM LOAD (Kg)	540	540	540
--------------------------	------------	------------	------------

MAXIMUM LOAD = MAXIMUM LOAD DISPLACEMENT – LIGHT DISPLACEMENT
--

ANY OVERLOADING CARRIES A RISK OF FLOODING OR LOSS OF STABILITY
--

III) ACCOMMODATION

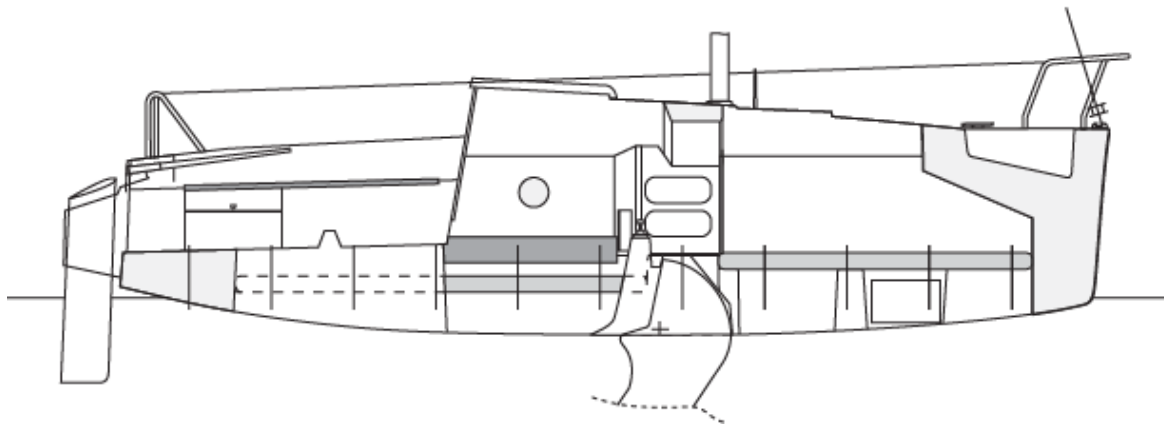
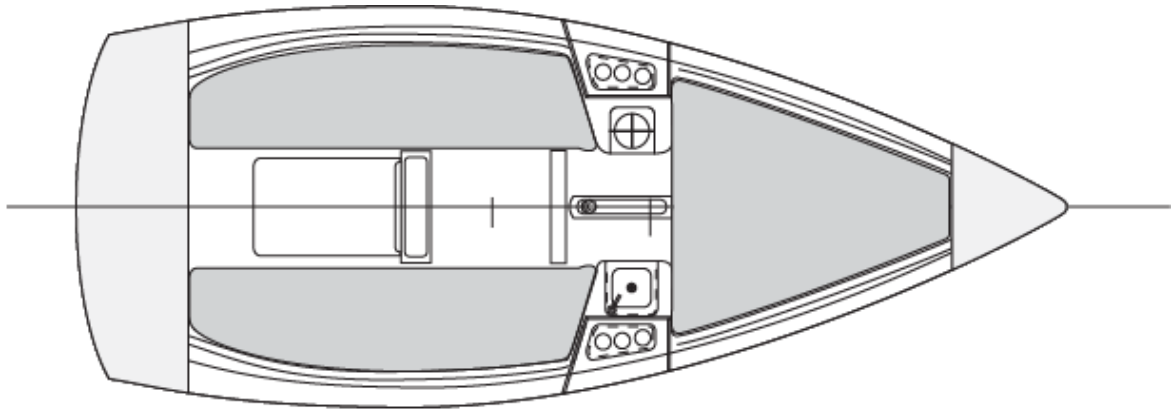

EXIT IN CASE OF FIRE

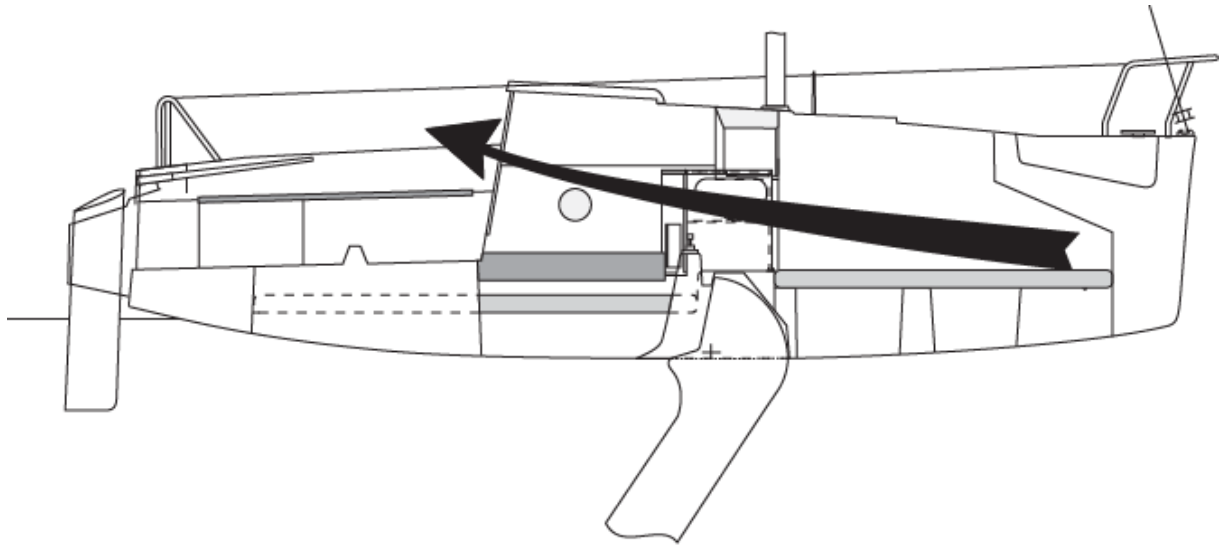

IV) DECK

- The safe lines can be fastened either on the mooring cleats or on the toe rail.

Some boats are fitted with a foldaway swimming ladder. The swimming ladder shall be in its usual place on the transom as soon as you are on board.

Make sure that the hatches and portholes are closed before you put out to sea.

In case of rough sea, close the boat with her door and washboard so that no water may come into the boat

Check that nothing blocks up the draining holes ; never seal them.

- ① Location of the life-raft

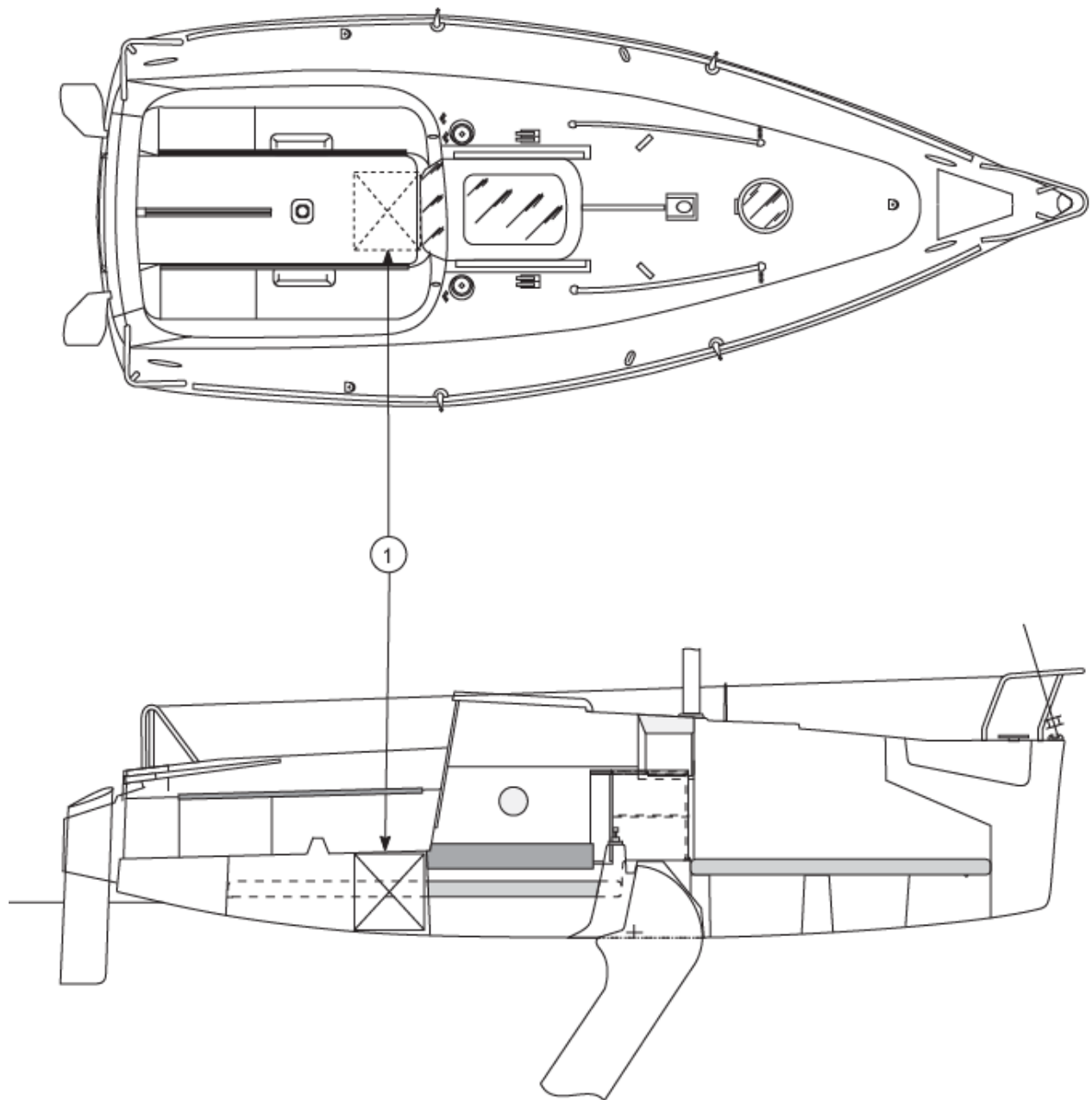

V) SAILS AND RIGGING

Specifications of the Sails :

SAIL	AREA m ²
Total	25.20 m ²
Main Sail	13.80 m ²
Genoa (maxi)	11.40 m ²
Spinnaker	34.70 m ²

I	8.59 m
J	2.40 m
P	8.24 m
E	2.85 m
LP	2.67 m

Specifications of the Standing Rigging:

V : Vertical - D : Diagonal

REF	CABLE	Ø mm
1	V1 (Shroud)	4
2	D1 (Lower Shroud)	4
3	Forestay	4
4	Preventer Backstay	3

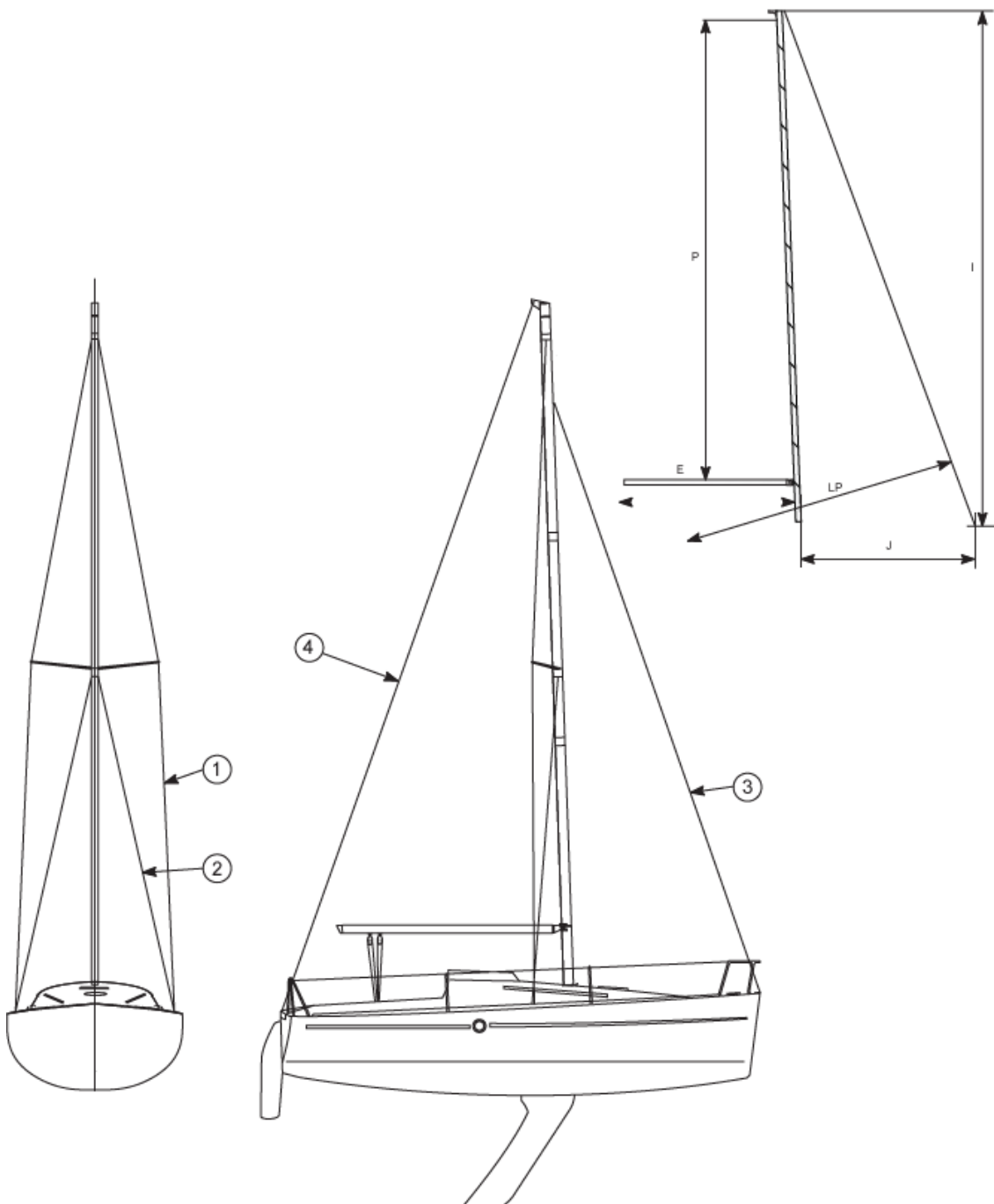

DECK FITTING LAY OUT

REF	STANDARD MAST
1	Genoa Furling Line
2	Mainsail Halyard
3	Reef n° 1
4	Spinnaker Boom Topping Lift
5	Reef n° 2
6	Spinnaker Halyard
7	Spinnaker Boom Downhaul

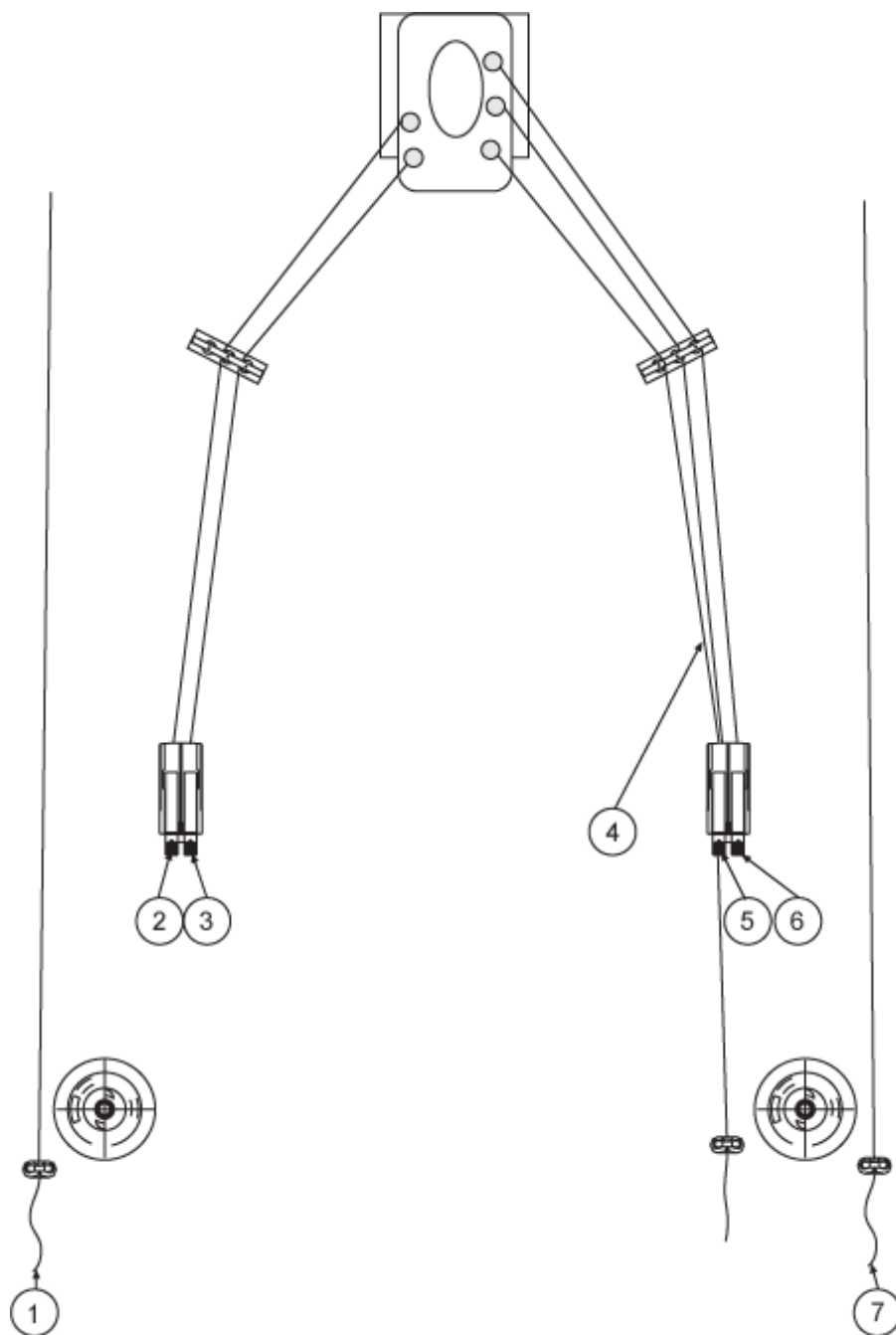

MAINSAIL TACKLE

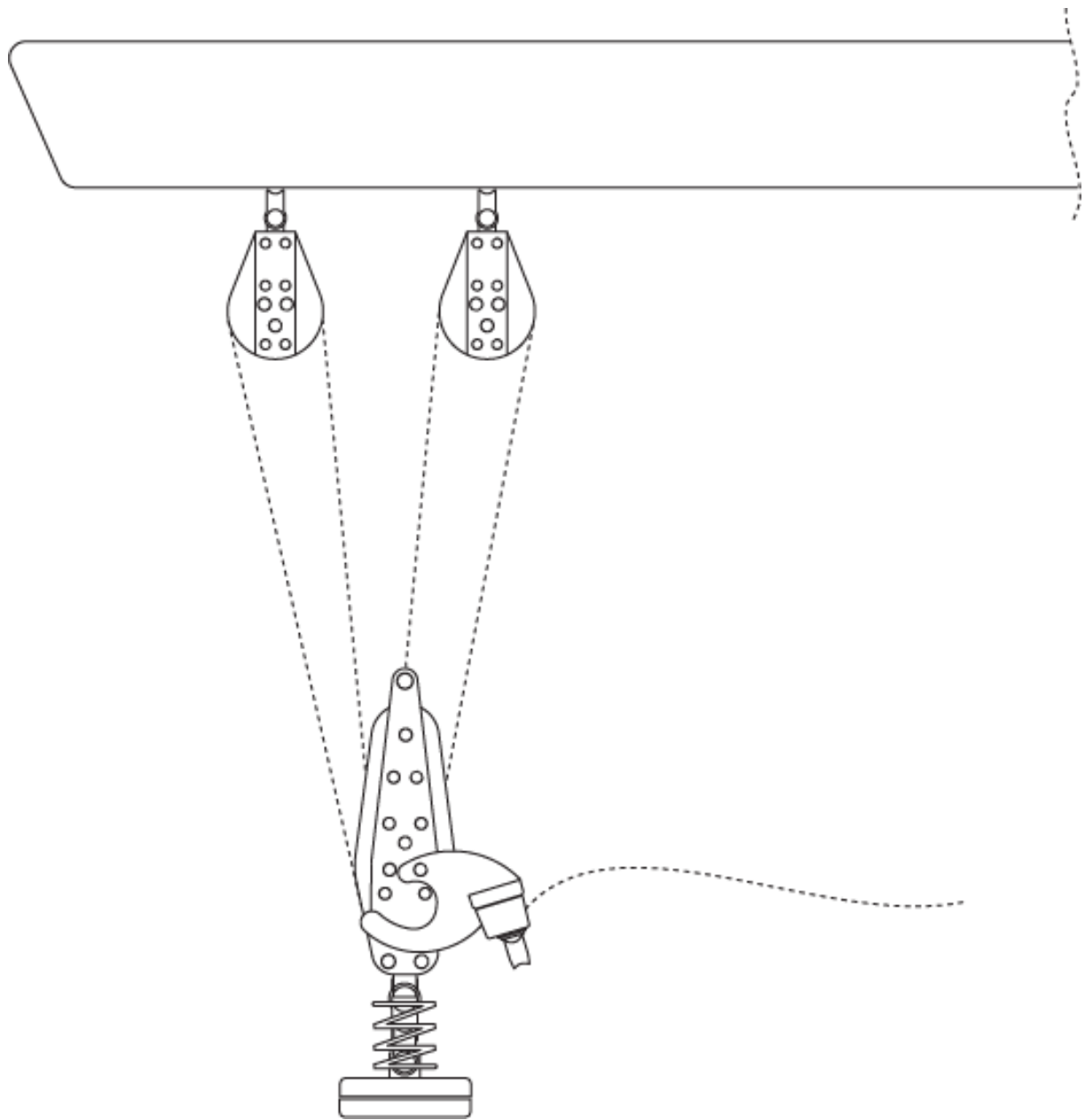

VI) FRESH WATER SYSTEM (OPTIONAL)

REF	DESCRIPTION
1	Water Tank 35 l
2	Hand Pump – Fresh Water
4	Filler – Fresh Water Tank
13	Galley Sink

The fresh water system supplies the sink in the galley and the washbasins. This supply is made depending on the models, either by a manual pump , or by an electric pump; before this pump there is a filter it is necessary to clean regularly.

Never run an electric pump when the tank is empty otherwise it might be irreparably damaged.

Never force the filling nozzle deep down the filler pipe in order to prevent any over pressure in the systems and keep an eye on the vent hole(s) through which the water in excess will be discharged.

When the system has not been used for a long period of time, the tanks and pipes shall be cleansed with an acetic acid solution (white vinegar)

The water flows out from the sink and wash basins through their own skin fitting seacocks ; Close them when the water system is not used.

LAY OUT OF THE FRESH WATER SYSTEM

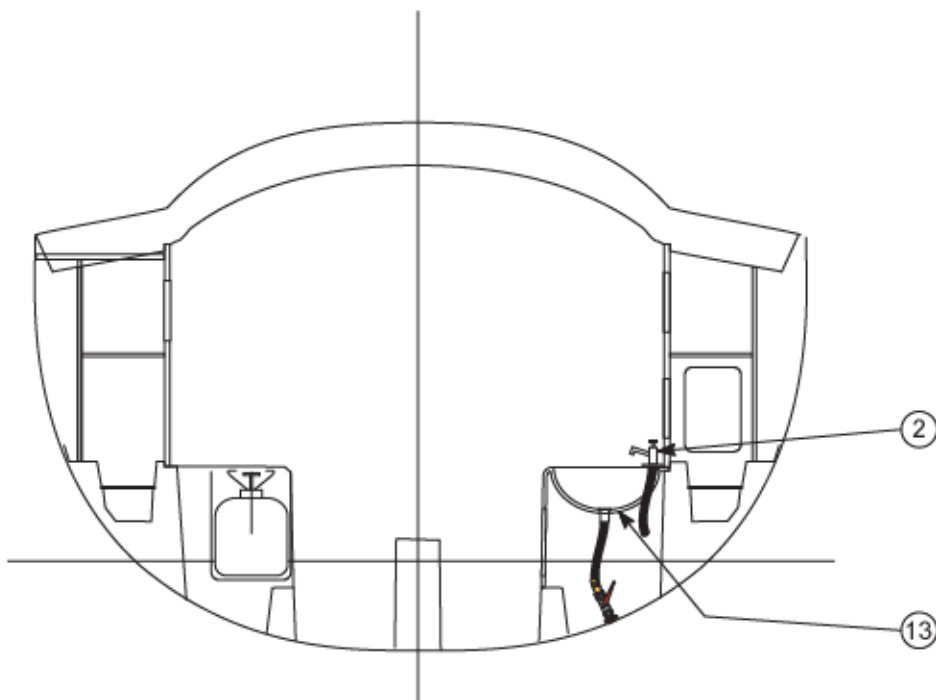
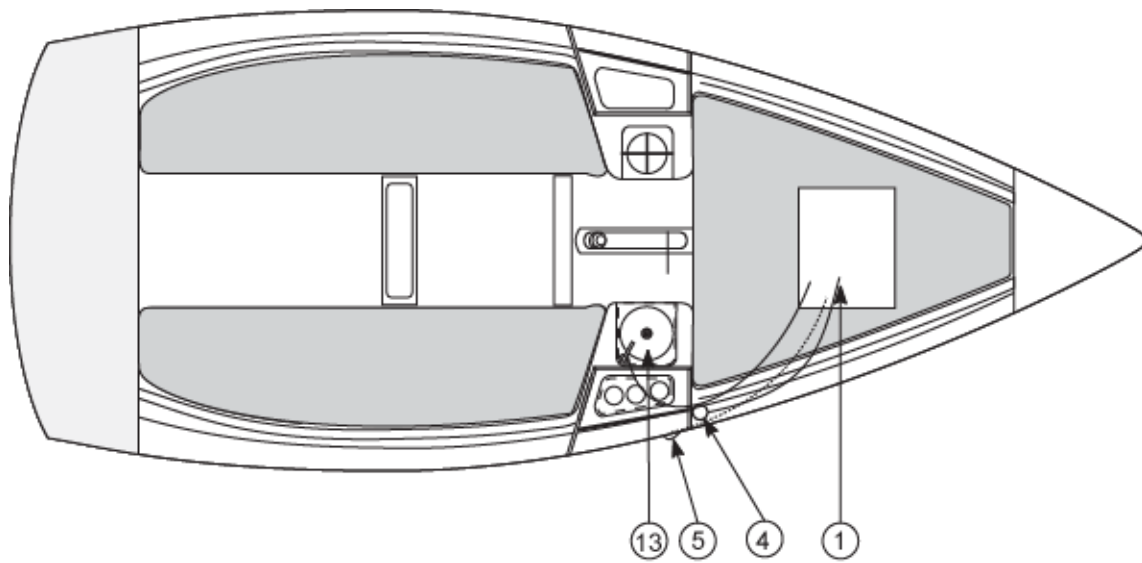

VII) BILGE PUMP SYSTEM

REF	DESCRIPTION
1	Inside Manual Bilge Pump 0.75 l/mn
2	Outside Manual Bilge Pump 1.9 l/each time
3	Inside Bilge Pump Intake
4	Outside Bilge Pump Intake
5	Inside Bilge Pump Delivery
6	Outside Bilge Pump Delivery

Make sure the bilge pump system is in good working order before you put out to sea.
--

Make yourself acquainted with the way the bilge pump system of your boat works :

- Locate the manual bilge pump and the handle which enables you to make it work.

- Locate the on switch of the electric bilge pump and get to know how the seacocks work (for the boats fitted with an electric bilge pump).

(See the lay out drawing of the system in the owner's handbook)

Make sure that the bilge pump intake strum box is not blocked with dirt.

Regularly clean the intake strum box on the sump and the filter of the system in case of an electric pump.

LAY OUT OF THE BILGE PUMP SYSTEM

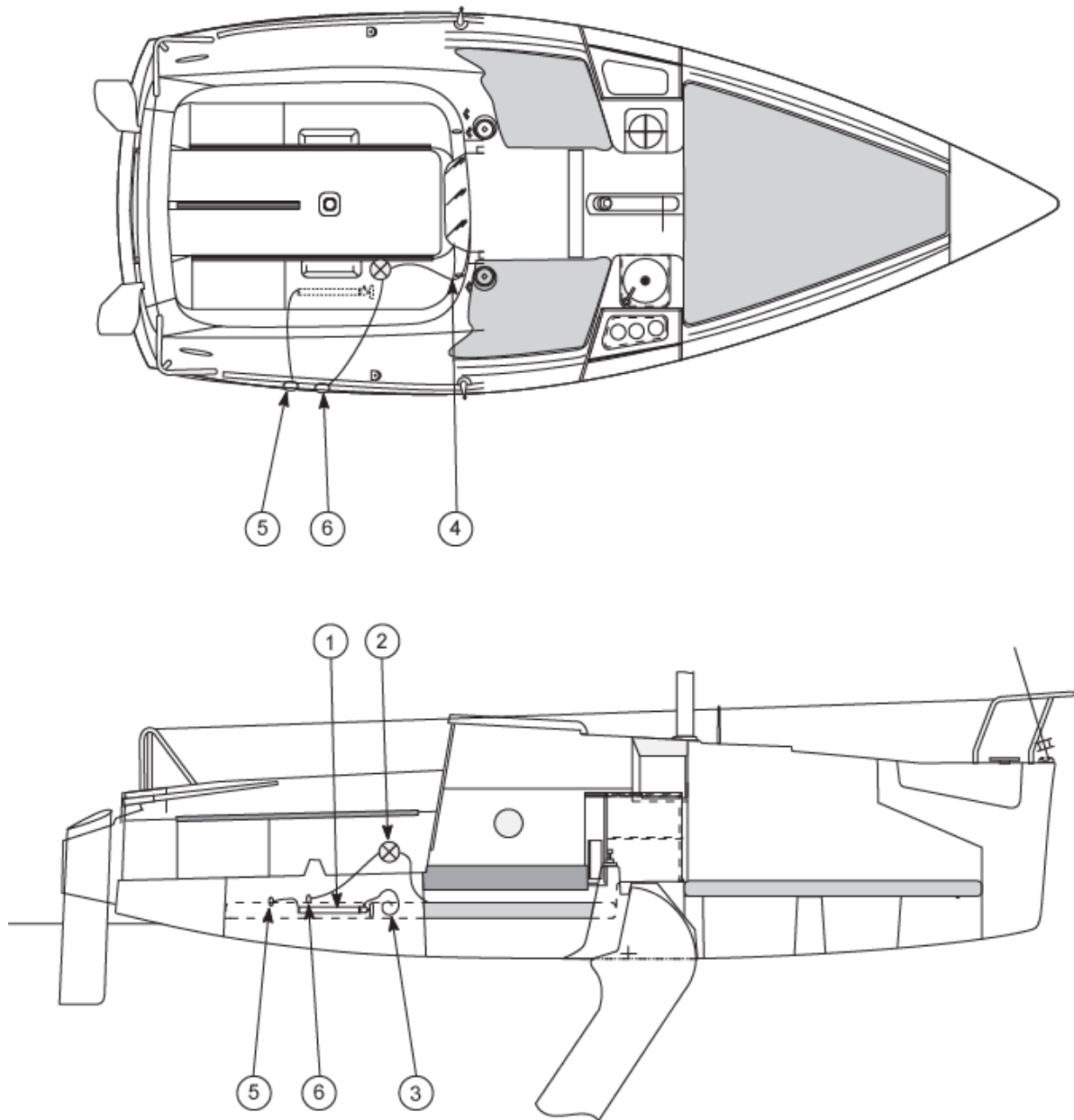

VIII) SEACOCKS AND SKIN FITTINGS

Close all the seacocks when you leave the boat.

The flushing toilets may be situated below the waterline ; get into the habit of systematically closing the seacocks after each use.

Make sure that all the seacocks which are not used are closed before you put out to sea. (in the owner's manual, see the drawing where the lay out of the skin fittings is shown).

Opening and closing of the seacocks

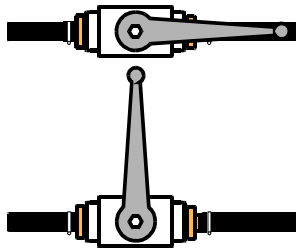

Open

Closed

REF	DESCRIPTION
1	Washbasin Outlet

SEACOCK AND SKIN FITTING LAY OUT

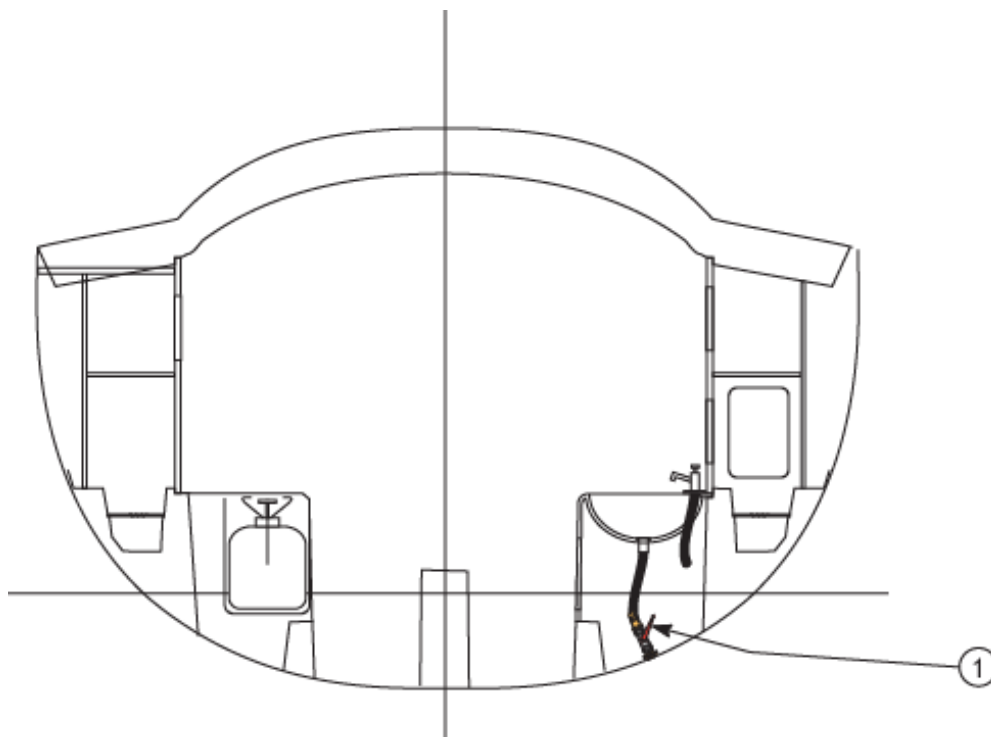

IX) ELECTRIC SYSTEMS

When the voltage is not specified, all the functions or panels are in 12 Volts.

12V Electric System**Never work on a live electric fitting.**

Never tamper with an electric fitting. Call in a technician qualified in marine electricity.

The batteries must be carefully and safely stowed.

In order to prevent a short circuit between the battery terminals, do not store conductive objects near the batteries (e.g. metal tools, ...)

Never alter the specifications of the devices which protect against overstrength.

Never fit or replace the electric materials or appliances by components which exceed the system amperage.

110V-220V Electric System

Some boats are fitted with a 110V or a 220 V system (some as standard, others as an option, depending on the models). We advise you to follow the below mentioned steps in order to avoid the risks of electric shocks and of fire.

Do not work on a live fitting.

Connect the boat / shore supply cable in the boat before you plug it into the shore supply socket itself.
--

Do not immerse the boat / shore cable sockets.

Switch off the shore supply with the switch on board before you plug in or unplug the boat / shore supply cable.

Do not tamper with the connections of the Boat / shore supply cable. Use only compatible connections.

ELECTRICITY LAY OUT

2 Function Panel

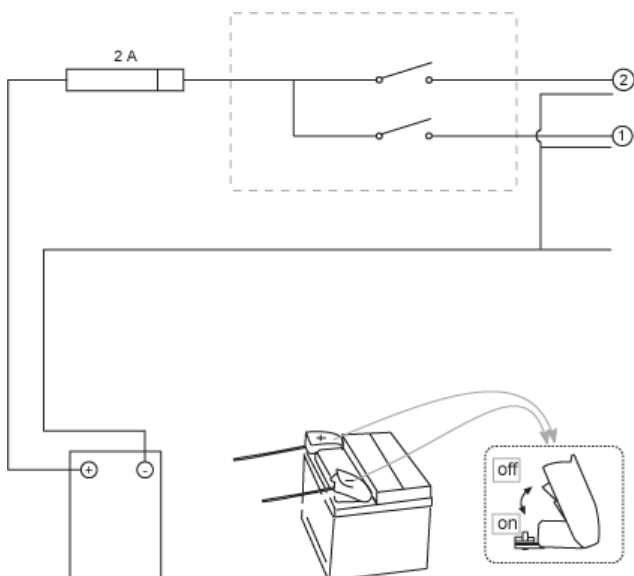

6 Function Panel (OPTIONAL) :

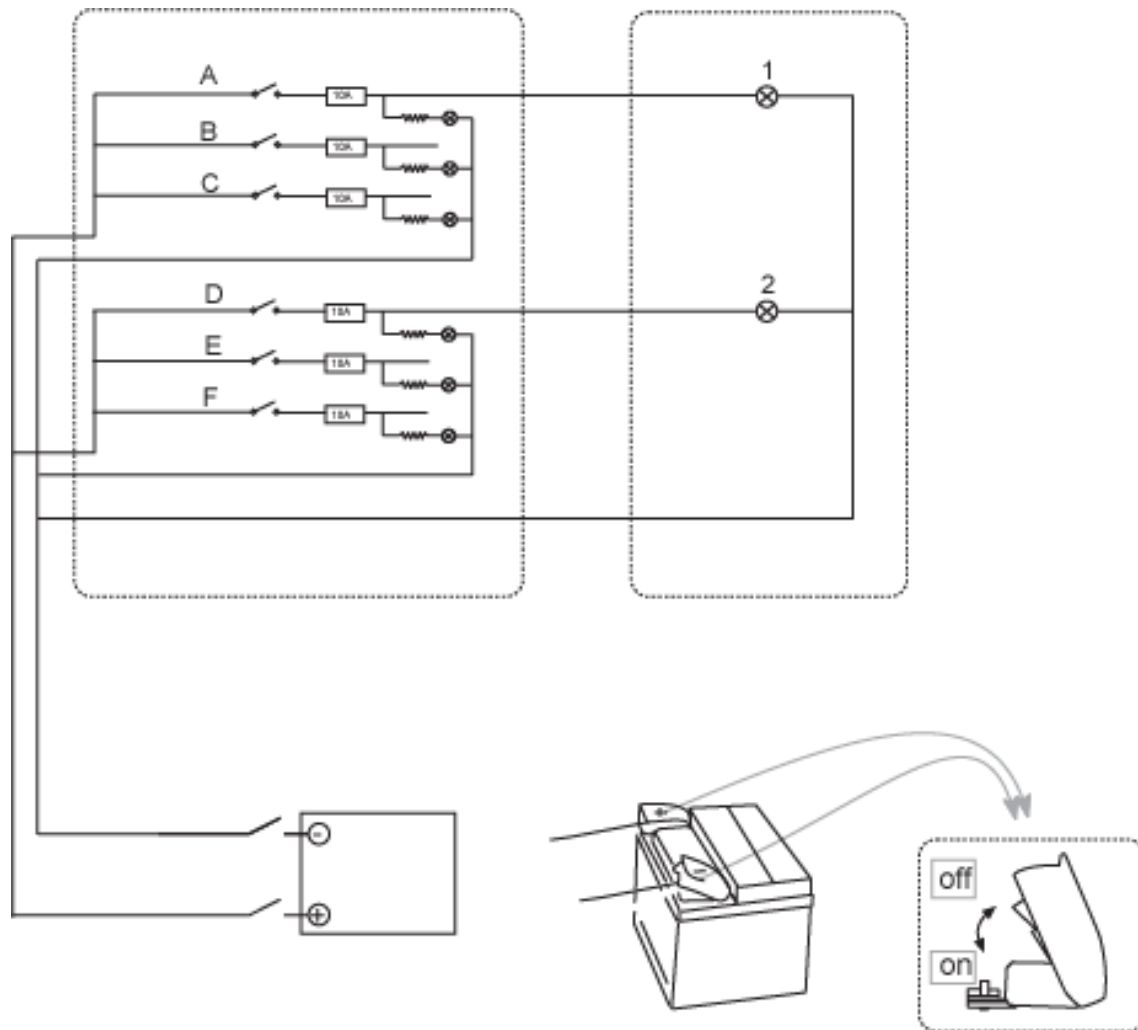

LAY OUT OF THE 12V LIGHTS AND APPLIANCES

On the 2 function panel :

REF	DESCRIPTION	N°
1	Mast Head Light	1
2	Inside Light	2

On the 6 function panel :

REF	DESCRIPTION	N°
A	Navigation Lights	1
B	Mooring Light	
C	Navigation	
D	Inside Light	2
E	Bilge Pump	
F	Spare	

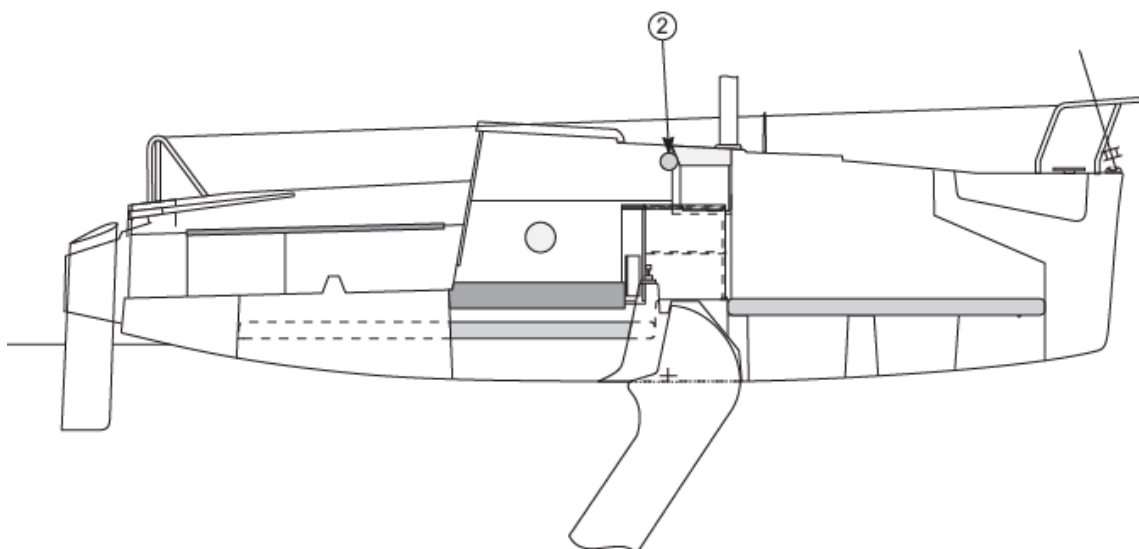
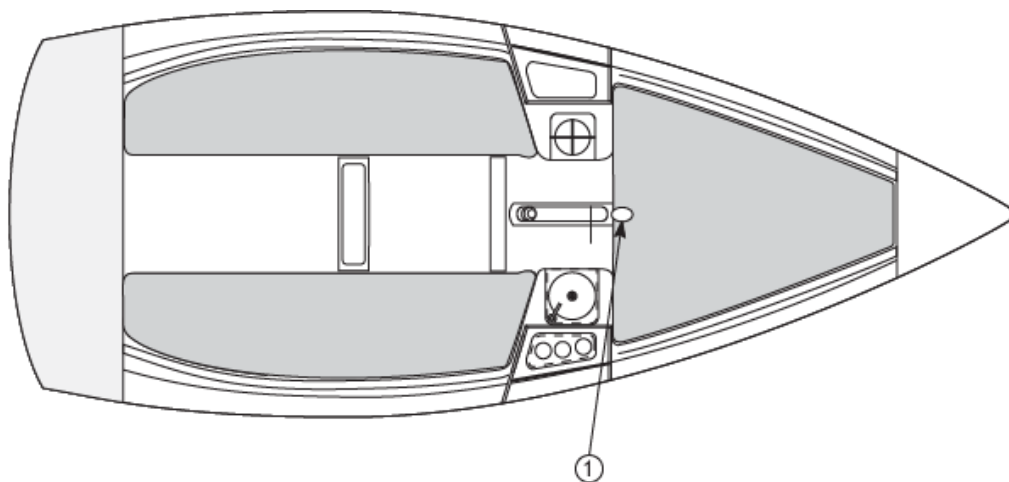
12V LIGHT AND APPLIANCE LAY OUT

X) GAS SYSTEMGas Stove

The boat is delivered without any fire extinguisher. It is your own responsibility to comply with the laws and regulations of your own country (Number, capacity, type and place of fire extinguishers). We advise you at least to install an extinguisher less than 5 metres away from each berth, less than 2 meters away from the extinguisher aperture in the engine compartment, less than 2 meters away from any naked flame device and less than 1 meter away from the helm pedestal. We advise a total capacity of the portable extinguishers reaching 8A/64B, each extinguisher having at least a 5A/34B capacity. The CO2 extinguishers shall be used to fight fires in the galley or electric fires.

Do not fit or store flammable materials above or over the stove (Curtains, papers, napkins, and so on.....).

Never leave the boat unattended when the gas or spirit appliances are working.

The appliances which use fuel consume the oxygen within the cabin and release the combustion products into the boat. It is necessary to ventilate the boat when the gas cooking appliances are working. Do not obstruct the air vents of the boat.

Do not smoke or use a naked flame when you are trying to locate a gas leak or when you change the gas bottle or whenever you intervene on the gas system.

If you smell gas or find that the burners have gone out, by accident, (although appliance models cut off the gas automatically if the flames go out) turn off the gas taps and do ventilate the boat in order to get rid of any residual gas. Find the root of the problem.

For the stoves with an integral gas cylinder you shall change the cylinder outside the boat. Test the stove before you put it back in the galley. Pay particular attention to the stove fittings and make sure the stoves are locked after they have been put in their places.

Do not use cooking appliances to heat the inside of the boat.

Make sure that the taps of the burners are turned off before you turn on the tap of the hoses and of the cylinder.

Turn off the tap on the feed hose and the taps on the cylinders when you do not use the appliances.

Do not obstruct the access to the gas system components, in particular the access to the taps (cylinders and gas cooker).

The flexible hoses which connect the gas cylinder at one end of the system and the stove at the other end, shall be changed in pursuance of the regulations in force in your country. Only use hoses which meet the safety standards of your country.

Do not use the gas cylinder storage space to store other equipments.

Pay particular attention to keep in good condition the screw thread of the cylinder on which the regulator is. Check the condition of the regulator every year and change it if necessary. Use a regulator identical to the ones which are fitted.

Make sure that the taps of the empty cylinders are turned off and disconnected from the system.

Do not use ammonia based products to clean it or to discover a leak.

Spirit Stove

Some boats are fitted with a spirit stove.

Do not smoke when handling the fuel.

Keep the fuel in a can for this purpose, a good distance away from the stove, the engine and any other sources of heat.

Follow the manufacturer's recommendations as far as the filling of the burners is concerned. Do not pour the spirit directly into the burner over the stove.

Only use methylated spirits. Petrol, oil, propane, diesel oil, fuel oil or other fuels and flammable materials are to be proscribed.

Any fuel overflow out of the burner tank shall be wiped up immediately.

LAY OUT OF THE GAS SYSTEM

REF	DESCRIPTION
1	Gas Stove
2	Tap to Turn On/Off the Gas

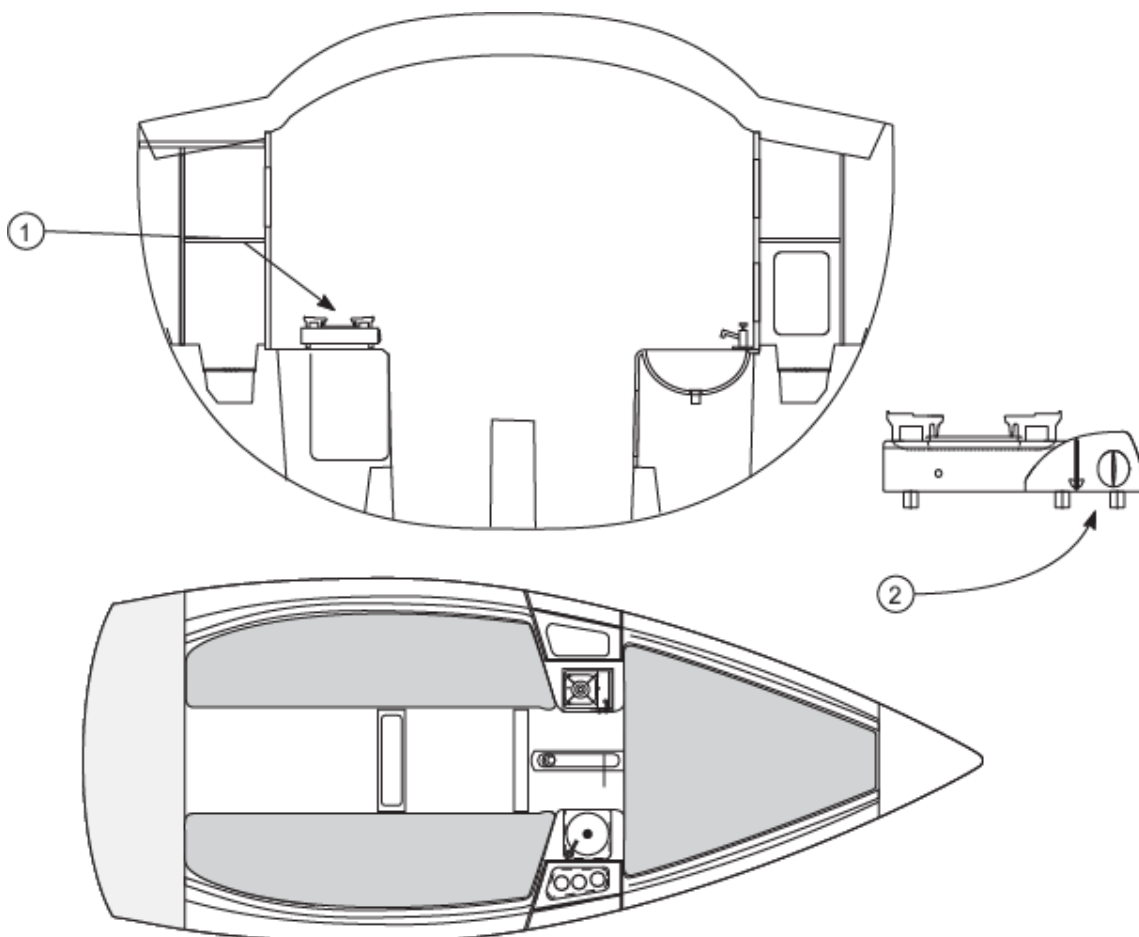

XI) STEERING SYSTEM, EMERGENCY SYSTEM

Boats who are fitted with a steering wheel carry an emergency tiller ; keep clear emergency tiller access.

Check once a year at least that the steering cables are tight properly.

Lift the aft hatch, open the cap, drive the emergency tiller into the print on the rudderstock head.

REF	DESCRIPTION
1	Tiller + Extension
2	Tiller Head
3	Tie-Rod
4	Rudder
5	Rudder Sleeve

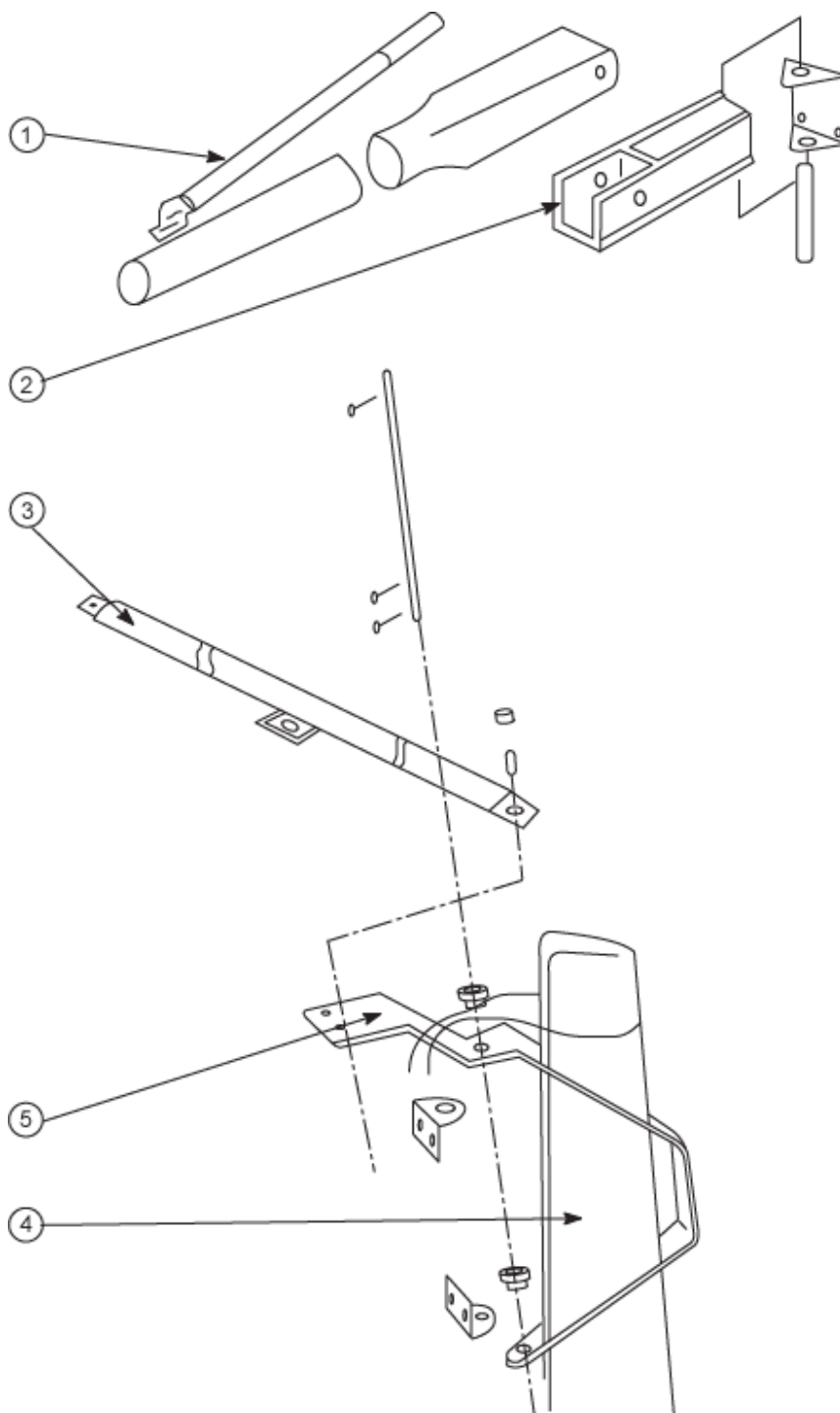

XII) MOTORIZATION

Stop the engine, do not smoke while you are filling up the fuel tank.

Before you start the engine, make sure that the engine compartment bilge is clean and dry. If there is the slightest presence of fuel in the bottom, you must not start the engine.

For the boats fitted with a petrol engine, ventilate the engine compartment for 5 minutes with the bilge ventilators so that the possible petrol vapours may be removed completely.

For the outboard engines with a spare can, fill up the portable tank outside the boat in a well ventilated place and away from any risk of possible fire.

The fuels that are stored outside the tanks (spare cans, jerrycans,...) shall be kept and stored in a ventilated place.

Know exactly where the extinguisher aperture is located in the engine compartment so you will be able to put out a fire breaking out in it.

A fixed system of extinguisher which enables you to put out a fire breaking out in the engine compartment bilge is fitted in the boats with petrol engines. Know where the release mechanism is and the way it works. It is necessary to ventilate the engine compartment after this mechanism has been released.

REF	DESCRIPTION
1	Outboard Engine
2	Outboard Engine Bracket

ENGINE LAY OUT (OPTIONAL)

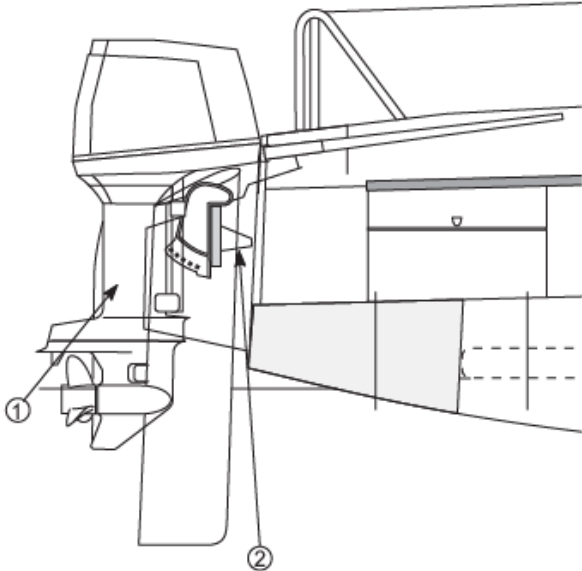

XIII) HANDLING

Contact your BENETEAU dealer for the maintenance and repairs of your boat. He will advise properly, will supply you with the spare parts you need or the materials that are suited to your boat.

Have your boat examined and maintained once a year during the winter storage.

POSITION OF CRANING STRAPS AND CRADLE POSITION ; POSITION OF THE LEG CHAINPLATES

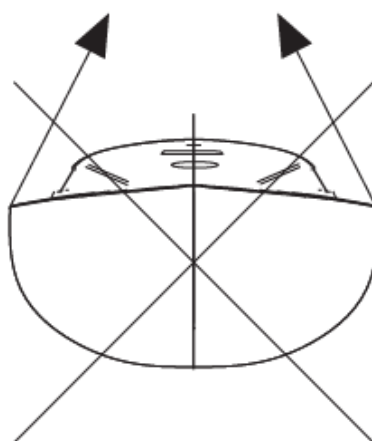
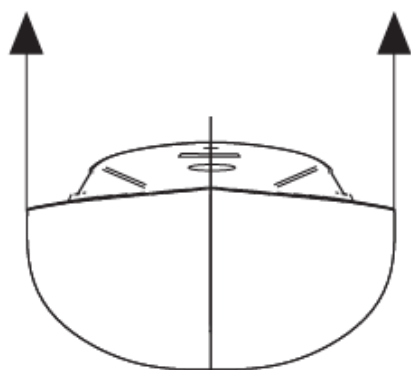
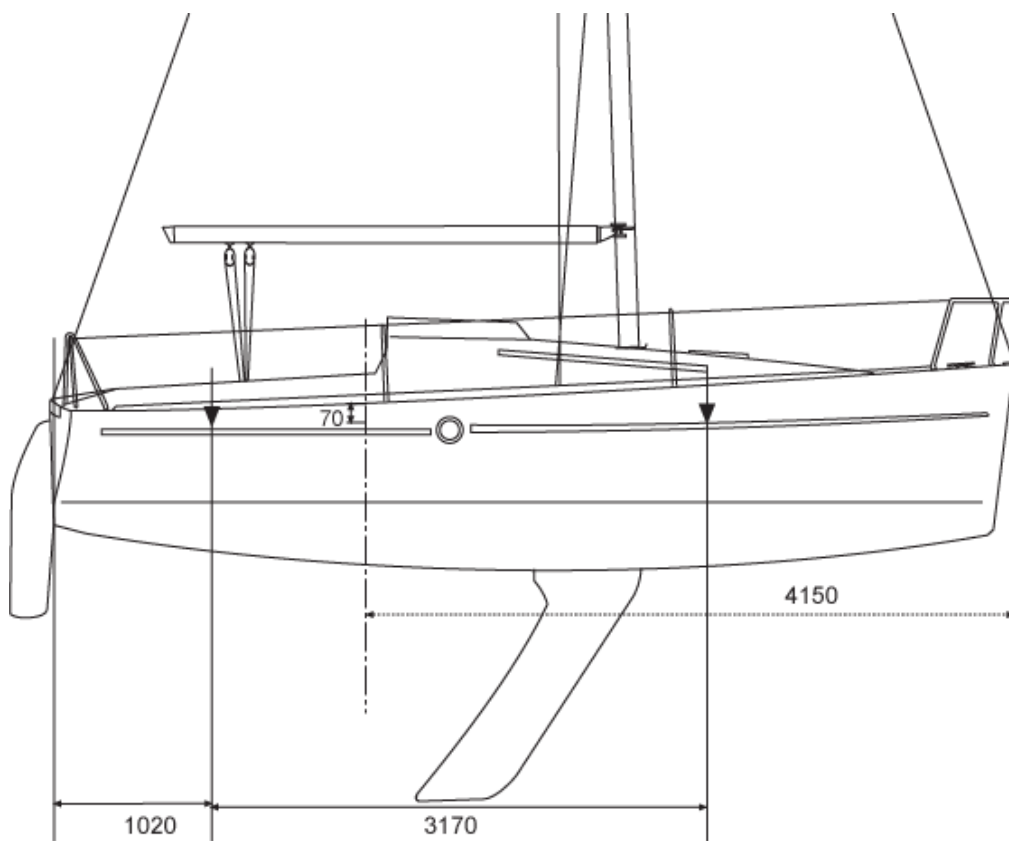
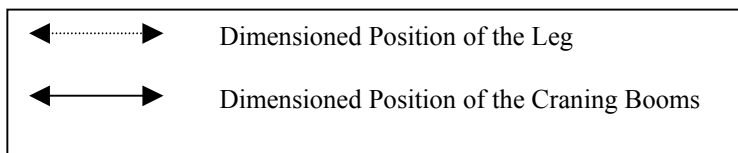

XIV) MAINTENANCE

Because you have chosen to invest your money in a recreational item that spends its life in a harsh environment, it is very important to ensure that your boat is well and regularly maintained. Furthermore, a fair number of accidents are due to negligence and the lack of maintenance. These two reasons (the protection of your property and safety) must make you become aware of the importance of a regular and thorough maintenance of your boat.

The advice you will find hereafter and your PERSONAL NOTES will help you.

1) THE HULL

It is in laminated GRP. It is made with high quality products. However it would be wrong to assert that it will keep its original condition for life if you do not give over to it a minimum care.

The gel coat is fragile and the knocks and scratches it might have when you manoeuvre might leave marks on it. Have always a member of your crew ready to put a fender at the right place.

It will be useful to hose off the hull and deck with fresh water, as often as you can.

Hull Preparation

Beforehand, you may apply on the gel coat an epoxy paint ; it will protect the bottom (the careen) of your boat against the natural attacks of the sea environment.

Moreover, the bottom shall be covered with a protective antifouling paint which will prevent the adhesion of the sea vegetation.

When you apply the antifouling paint, be careful : do not paint the anodes, the heads of the electronic instruments and do not obstruct the strainers of the water intakes, in particular the strainers of the engine-cooling system.

In all events, remove the grease from the bottom and slightly hand rub down with at least # 400 grit sand paper and water.

Maintenance

In order to keep the good looking gel coat of your boat, a preventive and regular maintenance of it is necessary. For this, do not hesitate to ask your dealer who will give you advice about the methods to follow and the most appropriate products to use.

2) THE DECK

Regularly rinse the deck and deck fittings with fresh water.

Regularly scrub the deck with a mild detergent liquid.

Deck Fitting :

Regularly lubricate the blocks, sheaves, turnbuckles, winches, windlass, rails, travellers, and so on with grease or light oil.

Polish with an appropriate polish paste the stainless steels which may have small pits or superficial oxidisation pits.

The Outside Teak Woodworks :

Scrub the woodworks using water.

The teak woodworks do not need any particular protection. If you just rub them down with fine sandpaper, it will renovate the look of the teak.

Plexiglass:

Rinse with fresh water. Clean them using a sponge and a cleaning product for windows.

The Rudder :

Every year have the whole steering system overhauled.

3) INSIDE

Whenever the weather makes it possible, air and ventilate regularly your boat, take off the floorboards, the berth spreads and put them vertically when you leave the boat.

Protect the inside of your boat as often as you can with the fitted curtains.

Make sure that the bilges are clean and dry.

The internal woodworks are varnished in most of our boats ; therefore you have to rinse them with fresh water and a liquid detergent, then polish them with a chamois leather.

The cleaning of the fabrics, cushions or lining of your boat depends on the materials used. Therefore you must contact a skilled specialist before you do anything.

Fresh Water System

It is possible to sterilize the tanks with Clonazone tablets (Dygerma in UK, or a product sold in your country and containing the equivalent molecule, i.e. Tosylchloramid) which are available at the Chemist's.

If the boat is not used for a long period of time, rinse the tanks and pipes with water and vinegar.

Engine

Have the whole drive system overhauled and maintained by a skilled mechanic and refer to the instructions by the engine manufacturer , These instructions are supplied with your boat.

Keep the fuel tank as full as you possibly can in order to avoid condensation.

4) RIGGING

You must examine once a year the running and standing rigging. Take advantage of this examination to maintain them.

Carefully rinse the running rigging with fresh water at the end of each season.

5) SAILS

Whenever it is possible, rinse the sails with fresh water and let them dry.

The sails cannot stand the sun and water ; therefore, unrig them whenever you can or at least protect them, using appropriate covers.

6) WINTER STORAGE

LAYING UP

Remove from the boat all the documents of the boat, the lines which are not useful to moor the boat, the supplies, the clothes, the safety equipment, the batteries, the gas cylinder, and so on...

Have your safety equipment overhauled.

During this laying up period, draw up a complete inventory of the equipment on your boat.

PROTECTION AND MAINTENANCE

a) Inside:

Drain the fresh water pipes and rinse them with water and vinegar.

Close the water intake seacocks (except if your boat is dried out), rinse and drain the toilets pans and pumps.

Store the sounder and speedometer heads.

Carefully drain and dry all the bilges.

Put the floorboards, the cushions and berth spreads vertically in order to favour the airing of the compartments.

b) Outside :

Rinse with plenty of water the hull, the deck, the deck fittings, lubricate all the mechanical and mobile parts.

Protect your boat with fenders and make sure that the mooring lines are taut

Fix the rudder so that it may not move

c) Engine :

Only a skilled mechanic can do the winter laying up of the engine. It will not be the same if the boat remains afloat or ashore.

ALL THESE RECOMMENDATIONS DO NOT MAKE UP AN EXHAUSTIVE CHECK LIST. YOUR DEALER WILL GIVE YOU THE ADVICE YOU NEED AND WILL CARRY OUT THE TECHNICAL MAINTENANCE OF YOUR BOAT

XV) ENVIRONMENT

Do not pour to the sea the oil you have just drained, use appropriate waste tanks.

When you fill up the engine tank, take all the precautions in order to avoid the hydrocarbon overflowing.

In the harbour, do not use the heads on board if they are not equipped with holding tanks.

The use of detergent contributes to the deterioration of the sea fauna and flora ; choose entirely biodegradable products for your cleaning operations.

Do not throw to the sea plastic bags and rubbish bags ; use the dustbins for this purpose in the places of call.

You love the sea, just as we do ; therefore help us to protect it and do not pollute it.

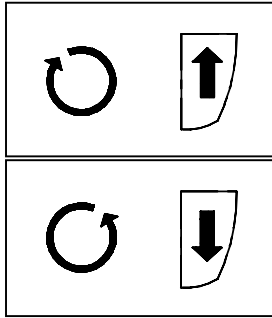
XVI) CENTREBOARD SYSTEM**Operation:**

To raise the centreboard, activate the mechanism clockwise.

To lower the centreboard, activate the mechanism anticlockwise.

About 57 rotations are necessary to go from one extreme position of the centreboard to the other.

In order to sail with the centreboard in the lower position, lower the centreboard to the maximum then pull it up by one or two turns so that the system should always be taut.

When you careen your boat, do not forget to lubricate the worm screw of the centreboard system, at least twice a year.

If your boat is fitted with a system to keep the centreboard in the lower position, the centreboard shall always be kept in its place.

NB : In order to get an optimum working steering system, we advise you to pull up the center board after each use.